





Ice Cube

# IC 24 HC



## Self-contained ice maker - Sprayer system Daily production up to 30 kg

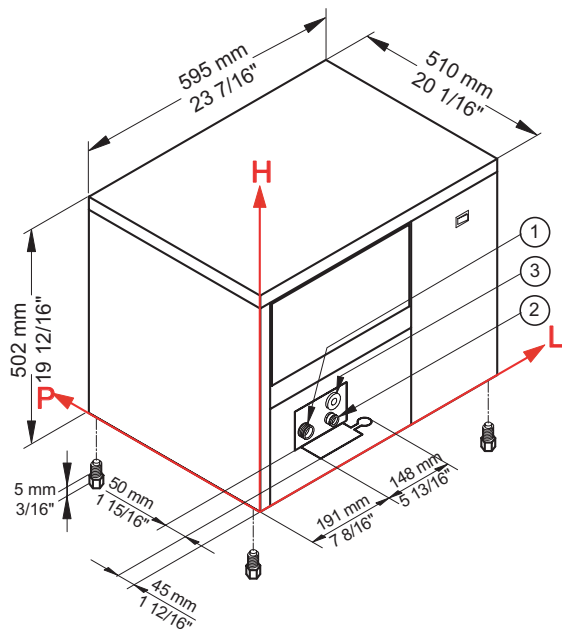

### ► Working conditions

- Location: Indoor

	Min	Max
Ambient temperature	+10° C / +50° F	+43° C / 110° F
Water temperature	+3° C / +37° F	+32° C / +90° F
Voltage	-10%	+10%
Water inlet pressure	1bar (14 psi)	6bar (84 psi)

### ► Performances

		Water temperature					
		7° C	45° F	15° C	60° F	21° C	70° F
Air temperature	10° C	30 kg					
	50° F		66 lbs				
	21° C			26 kg			
	70° F				57 lbs		
	32° C					20 kg	
	90° F						44 lbs

### ► Connections

All measures are referred to the rear bottom-left corner

- ① Water in.: 3/4" Ø
- ② Water out.: 24 mm / 15/16" Ø
- ③ Electrical connections

### ► Technical information

Production in 24h	26 kg / 57 lbs	Water consumption	A: 3,5 l/kg - 41,9 gal/100 lbs
Store capacity, up to	6 kg / 13 lbs	Sizes (L-P-H mm)	595 - 510 - 502
Cooling system	A	(L-P-H in)	23 7/16 - 20 1/16 - 19 12/16
Kind of cube	A-18g, D-13g	Sizes with pack (L-P-H mm)	635 - 555 - 650
Refrigerant	R290	(L-P-H in)	25 - 21 14/16 - 25 9/16
Standard voltage	220-240 V ~ 50 Hz	Net weight	38 kg / 84 lbs
Average power consumption	280 W	Gross weight	45 kg / 99 lbs
Fuse	10 A	Finish	AISI 304 stainless steel, scotch brite
Electrical Consumption	31 kWh/100kg		

All the technical information must be considered at the following conditions:

- Sizes without feet
- Standard Cube (13 g)
- Ambient temperature +21° C
- Water temperature +15° C
- Electrical consumption at +32° C (standard voltage)
- Average power consumption at +43° C (standard voltage)

Models and specifications are subject to change without notice

Rev. 00 - Issued March 2025



[www.bremagroup.it](http://www.bremagroup.it)  
info@bremagroup.it

We are Brema

