



XEVC-0511-EZLM

Project _____

Item _____

Quantity _____

Date _____

Model
CHEFTOP MIND.Maps™ ZERO COUNTERTOP

 **Energy efficiency 28.8 kWh/day - 0 kg CO₂/day***

*More details on the last page.

Combi oven	Electric
5 trays GN 1/1	Hinge on the right side
Control panel with 7-segment display	
Voltage: 380-415V 3N~ / 220-240V 3~ / 220-240V 1~	

Description

Concrete, robust and easy to use combi oven, ideal for handling traditional cooking processes (steaming, roasting and browning). It uses the STEAM.Plus technology to steam food and the AIR.Plus technology to distribute heat throughout the cooking chamber, ensuring uniformity and fast cooking times. Ideal for kitchens looking for maximum results, with minimum investments.



Standard cooking features

Programs

- 12 quick programs
- Store up to 99 programs

Manual cooking

- **Temperature:** 30 °C – 260 °C
- Up to 3 cooking steps

Advanced and automatic cooking features

Unox Intensive Cooking

- **DRY.Plus:** rapidly extracts humidity from the cooking chamber
- **STEAM.Plus:** creates instant humidity
- **AIR.Plus:** multiple fans with reverse gear and 2 speed settings





XEVC-0511-EZLM

Key features

- Cooking chamber in high-resistance AISI 304 stainless steel with rounded edges
- Double glass
- Cooking chamber lighting through LED lights embedded in the door
- Tray supports with anti-tip system
- Drip collection system integrated in the door which works even when the door is open
- 2-speed fan system and high-performance circular heating elements

App and web services

Accessories

- **Neutral cabinet:** recommended solution to optimize your kitchen layout and always have everything in the right place
- **Stand:** the multifunctional support ideal for storing trays safely and placing your oven at the perfect height to work
- QUICK.Load and trolley system
- **Cooking Essentials:** special trays

XEVC-0511-EZLM

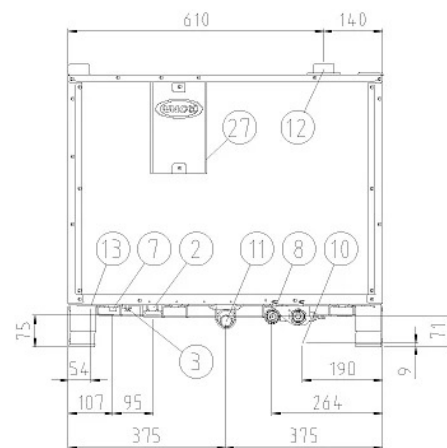
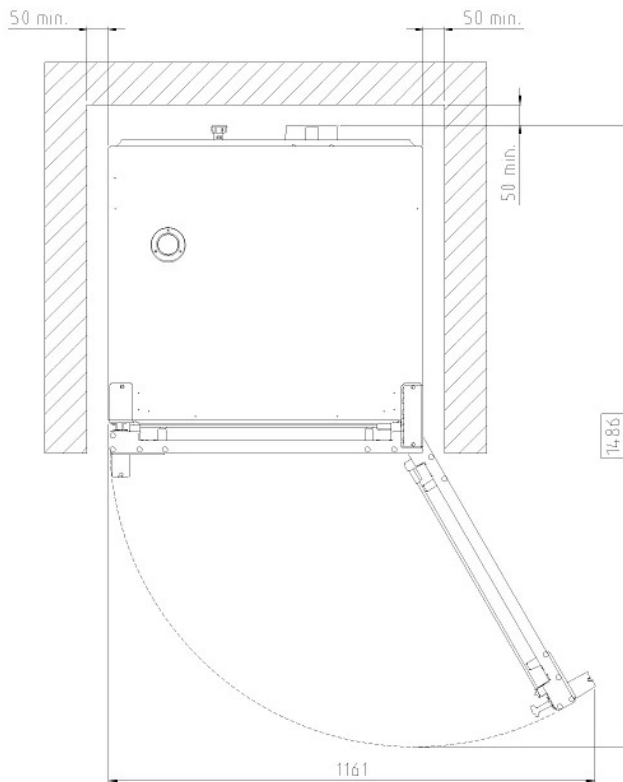
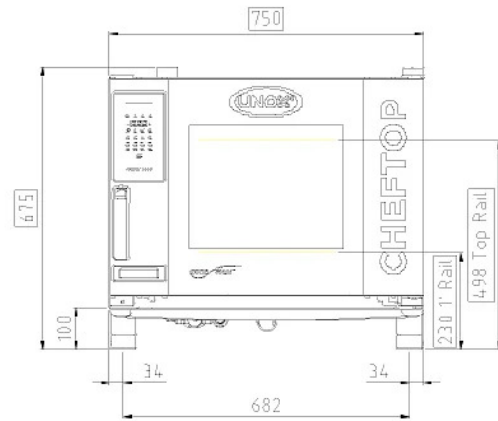
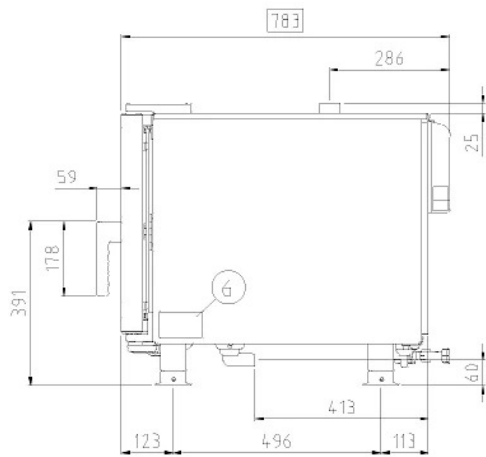

Dimensions and weight

Width	750 mm
Depth	783 mm
Height	675 mm
Net weight	61 kg
Tray pitch	67 mm

Connection positions

2	Terminal board power supply
3	Unipotential terminal
6	Technical data plate
7	Safety thermostat
8	3/4" female NPT water inlet
10	Rotor.KLEAN™ inlet

11	Chamber drain pipe
12	Hot fumes exhaust chimney
13	Accessories connection
27	Cooling air outlet



XEVC-0511-EZLM

Electrical power supply

STANDARD

Voltage	380-415 V
Phase	~3PH+N+PE
Frequency	50 / 60 Hz
Total power	9,3 kW
Max Amp draw	14 A
Required breaker size	16 A
Power cable requirements*	5G x 2,5 mm ²
Plug	NOT INCLUDED

OPTION A

Voltage	220-240 V
Phase	~3PH+PE
Frequency	50 / 60 Hz
Total power	9,3 kW
Max Amp draw	24 A
Required breaker size	32 A
Power cable requirements*	4G x 4 mm ²
Plug	NOT INCLUDED

OPTION B

Voltage	220-240 V**
Phase	~1PH+PE
Frequency	50 / 60 Hz
Total power	9,3 kW
Max Amp draw	41 A
Required breaker size	50 A
Power cable requirements*	3G x 10 mm ²
Plug	NOT INCLUDED

**Electric connection kit

Item	XUC129
Voltage	220-240 V
Phase	~1PH+PE

*Recommended size - observe local ordinance.

Energy efficiency

Consumption

CO₂ emission

**The estimate includes only direct emissions produced by the oven. Indirect emissions can be reduced to zero by choosing to purchase energy from renewable sources.

Estimate based on daily use of the oven (300 days/year):

6 light loads of roast chickens (loaded at 20%), 1 full load of roast potatoes, 3 full loads cooking with steam 2 hours in an empty oven at 180 °C.

Estimated assuming the following weekly washing programs (42 weeks/year):

1 long wash, 1 medium wash.

Installation requirements

Installations must comply with all local electrical systems, particularly as for minimum wire gauge required for field connection, hydraulic and ventilation supply. Exhaust and fume analysis must be performed in case of gas ovens.

Register to DDC Service to access data and product specifications.
www.ddc.unox.com