

GM 1500
Split CO₂



FROZEN SNOW



Modular ice maker 720 kg - Granular system

● Position n°



● Application fields

Hotel	●●●●●●●●●●	Fish market	●●●●●●●●●●
Restaurant	●●●●●●●●●●	Supermarket	●●●●●●●●●●
Fast food	●●●●●●●●●●	SPA	●●●●●●●●●●
Bar	●●●●●●●●●●	Medical	●●●●●●●●●●
Disco	●●●●●●●●●●	Industry	●●●●●●●●●●

● Features & Plus

- Granular ice
- 1 m³ = 550 kg of ice
- Low consumption (1 liter water / 1 kg ice)
- External structure AISI 304 Scotch Brite
- Monoblock Stainless steel frame
- Evaporator AISI 304, auger AISI 303 made
- Standard and special voltages
- ON-OFF switch
- Dust proof water basin
- Rotation sensor directly on evaporator
- Conformity to RoHS directive
- Automatic water charge
- Model in Tropical Class + 43 ° C
- Pressure limiting valve, PS up to 40 bar

● Usable Bins

- Bin PE530
- Bin T250
- Bin T420
- Bin T830
- Bin 1200DD
- RB 140
- RB 280
- DRB 1100
- DRB 2500

2 Years
Warranty

subject to limitations

● Certifications available for this model



N.T.F. S.r.l. Nuove Tecnologie del Freddo

Via dell'Industria 10/B
20020 Villa Cortese (MI), Italy

tel. +39 0331 436217
fax +39 0331 436218

www.ntfice.it
info@ntfice.it



ntfice.it





Modular ice maker 720 kg - Granular system

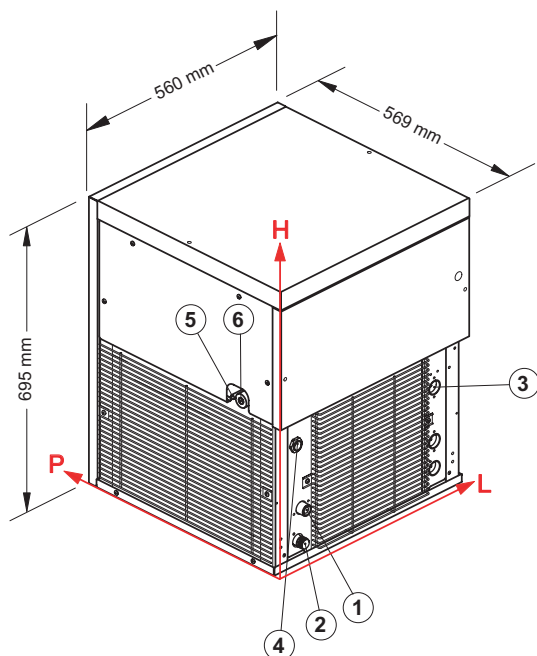

• Connections

All measures are referred to the rear bottom-left corner (L-H-Ø)

- ① Water inlet:
85,5 mm - 130 mm - 3/4"
- ② Water Outlet:
75,5 mm - 55 mm - 24 mm
- ③ Remote connection:
479,5 mm - 260 mm
- ④ Electrical connection:
67,5 mm - 290 mm
- ⑤ Refrigerant feeding pipe
- ⑥ Outlet pipe of gaseous refrigerant

• Working conditions

- Location: Indoor

	Min	Max
Ambient temperature	+10° C	+43° C
Water temperature	+3° C	+32° C
Voltage	-10%	+10%
Water inlet pressure	1bar (14 psi)	6bar (84 psi)

• Technical information

Production in 24h	720 kg
Refrigerant	CO ₂ (R744)
Refrigerant capacity	2300 W (evap. temp. -18° C)
PS suction side	580 PSI - 40bar
Standard voltage	220-240 V ~ 50 Hz
Electrical consumption	175 W
Sizes (L-P-H mm)	560 - 569 - 695
Sizes with pack (L-P-H mm)	645 - 645 - 910
Net weight	67 kg
Gross weight	77 kg
Finish	AISI 304 stainless steel, scotch brite

All the technical information must be considered at the following conditions:



Refrigerant capacity
2300 W
(evap. temp. -18° C)



Water temperature
+15° C



Electrical consumption
at +43° C
(standard voltage)

Models and specifications are subject to change without notice
Rev. 00 - Issued January 2017

